

# NON-ELEVATED BLEACHER

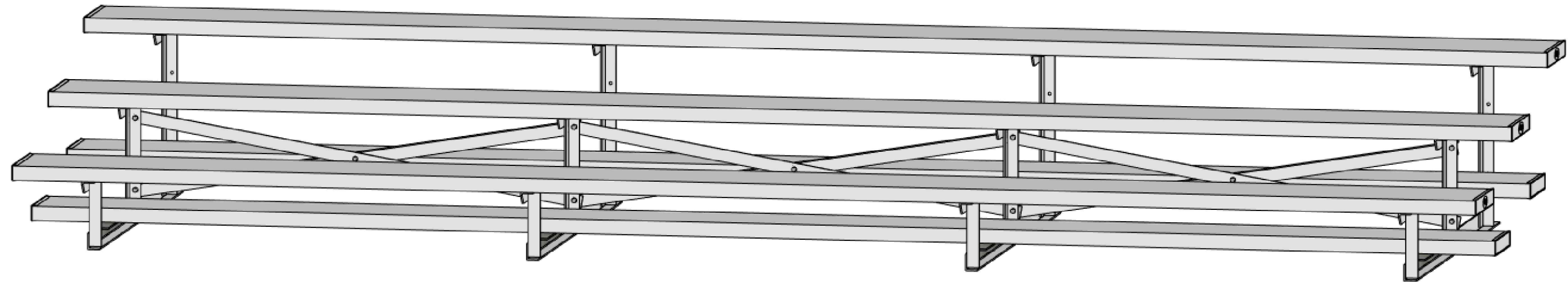

2810 Sydney Road  
Plant City, Florida 33566  
Phone: 813-305-1415  
Fax: 813-305-1419  
www.gtgrandstands.com

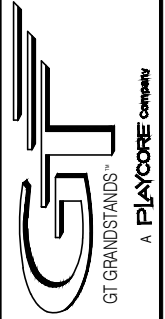

**ALUMINUM 3 ROW x 15'-0" - UNIVERSAL SERIES**

MODEL  
**LU-0315AS**

COVER SHEET  
3 ROW BLEACHER  
6" RISE/12" SEAT

LU-0315AS  
OPTIONAL -MS (MUD SILL)  
OPTIONAL -RB (RUBBER BUMPERS)

DRAWN BY  
MME  
CHECKED BY  
DATE  
07/18/17  
SCALE  
JOB NO.

CS.1 - COVER SHEET  
SP.1 - BLEACHER SEATING PLAN  
FB.1 - FRAME AND BRACING  
BA.1 - BLEACHER ASSEMBLY  
FP.1 - FOUNDATION PLAN

LU-0315AS  
DWG NO.  
**CS.1**

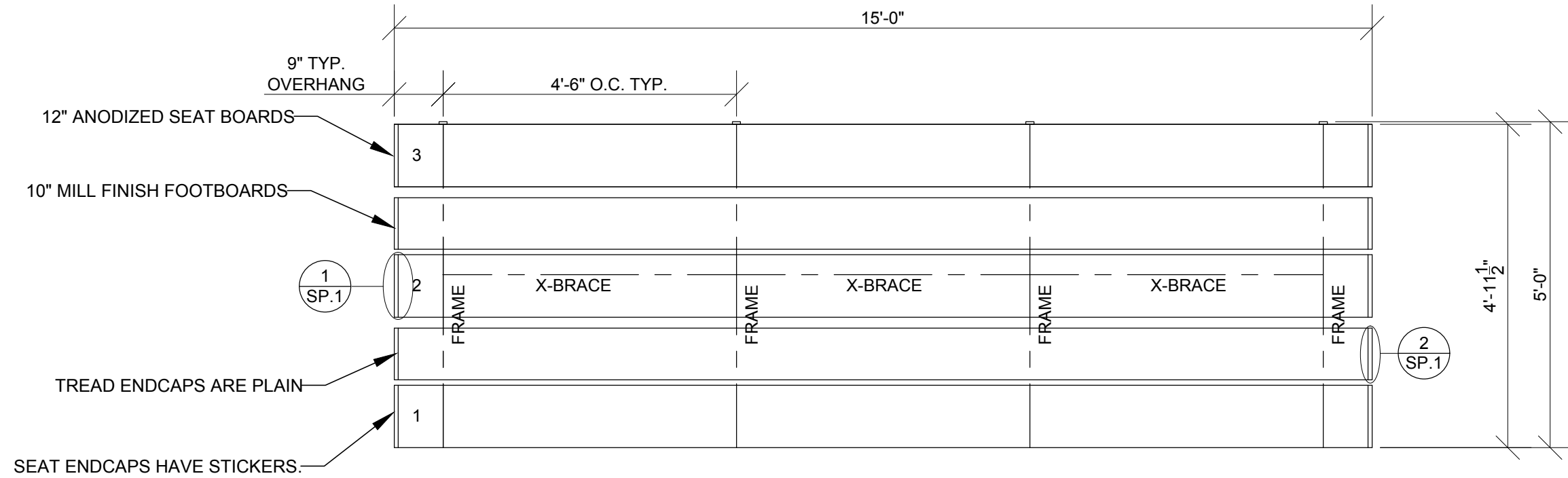
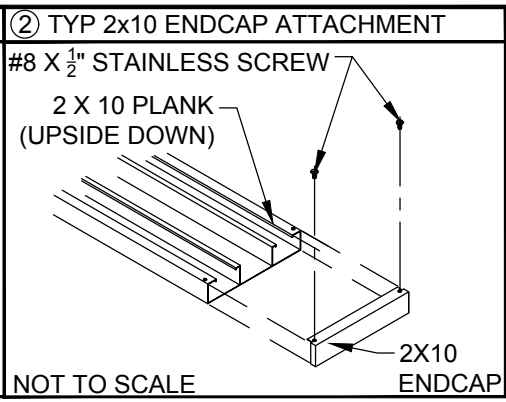
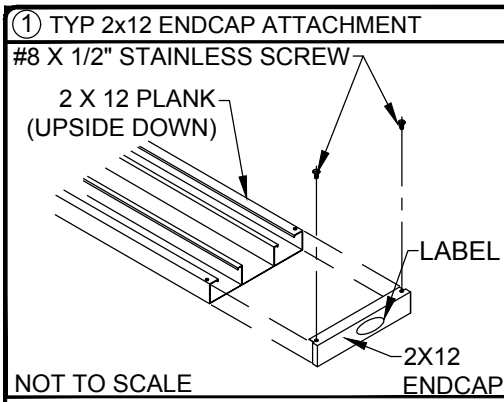

**SEATING PLAN**  
SCALE: 1/2" = 1' - 0"

SECTION LENGTH	GROSS SEATS	ACTUAL SEATS	NO. OF ROWS	NET SEATS
15	10.00	10.00	3	30
				NET SEATS 30
				WHEELCHAIR SPACES 0
				<b>TOTAL NET SEATING CAPACITY 30</b>
				(BASED ON 18" PER SEAT)

LOCAL CODES AND SPECIFICATIONS WILL VARY FROM REGION TO REGION AND WILL ALSO CHANGE OVER TIME. IT IS THE BUYER'S RESPONSIBILITY TO CHECK LOCAL CODES FOR COMPLIANCE.



2810 Sydney Road  
Plant City, Florida 33566  
Phone: 813-305-1415  
Fax: 813-305-1419  
www.gtgrandstands.com

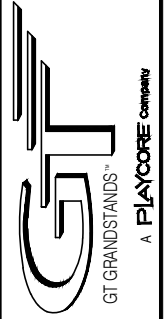

SEATING PLAN  
3 ROW BLEACHER  
6" RISE/12" SEAT

LU-0315AS  
LU SERIES

DRAWN BY MME
CHECKED BY
DATE 07/18/17
SCALE 1/2" = 1' - 0"
JOB NO.
LU-0315AS DWG NO.
SP.1

① TYP X-BRACE CONN. W/ 1 1/4" BOLT

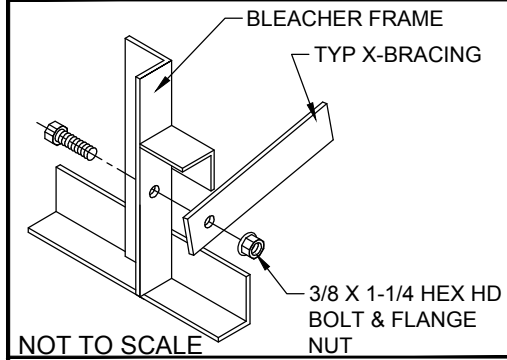

② TYP X-BRACE CONN. W/ 1 1/4" BOLT

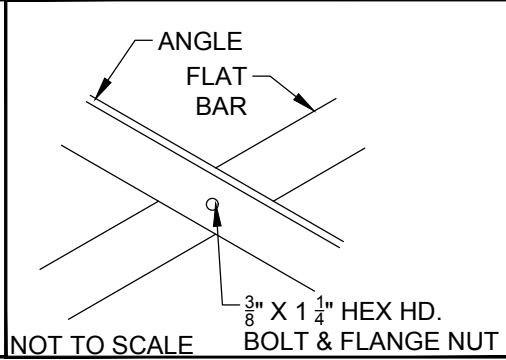

○ RUBBER FOOT PAD ATTACH. DETAIL

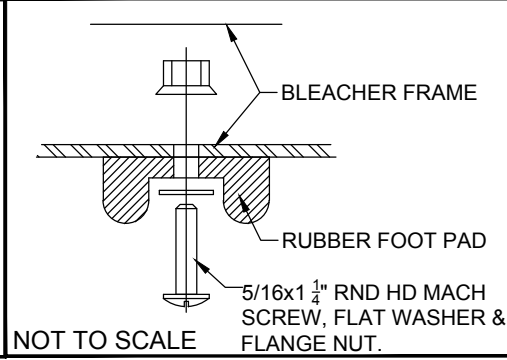

○ (OPTIONAL) MUD SILL ATTACHMENT

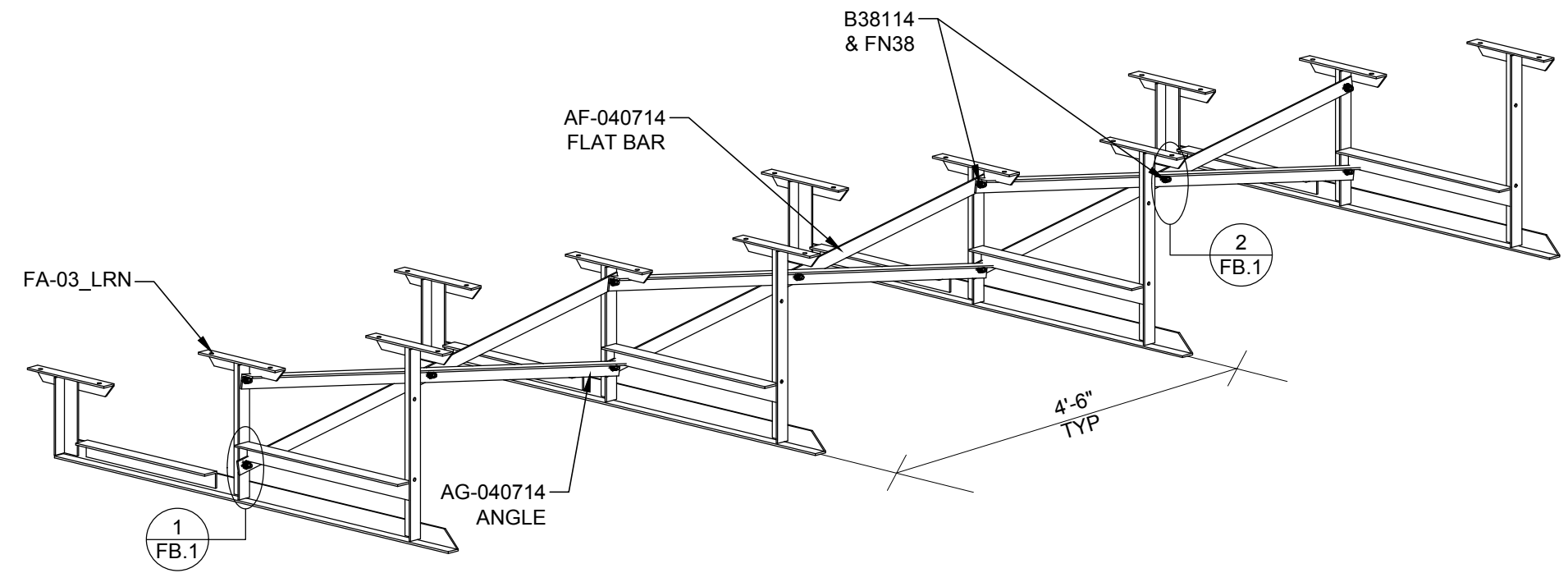
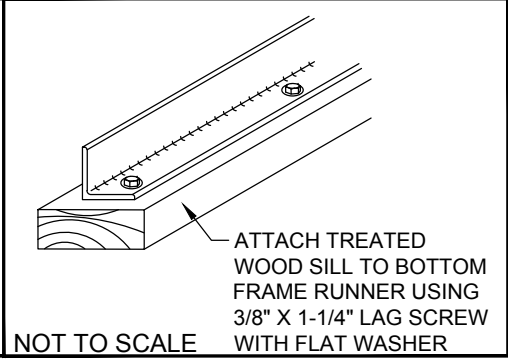

**FRAME SECTION**  
SCALE: NTS



2810 Sydney Road  
Plant City, Florida 33566  
Phone: 813-305-1415  
Fax: 813-305-1419  
www.gtgrandstands.com

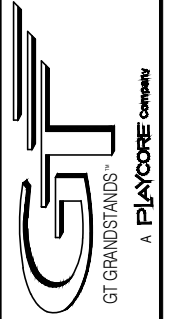

FRAME AND BRACE  
3 ROW BLEACHER  
6" RISE/12" SEAT

LU-0315AS  
OPTIONAL -MS (MUD SILL)  
OPTIONAL -RB (RUBBER BUMPER)

DRAWN BY  
MME  
CHECKED BY  
DATE  
07/18/17  
SCALE  
AS SHOWN  
JOB NO.

LU-0315AS  
DWG NO.

FB.1

② TYP 2X10/2x12 PLANK ATTACH

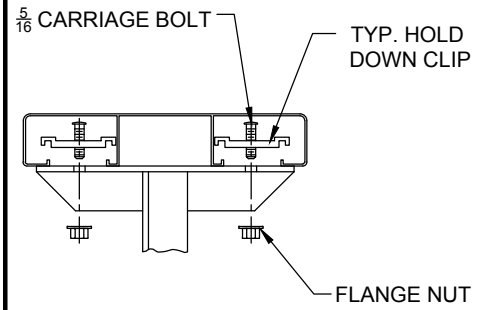

NOT TO SCALE

② OPTIONAL ANCHOR WEDGE DETAIL\*

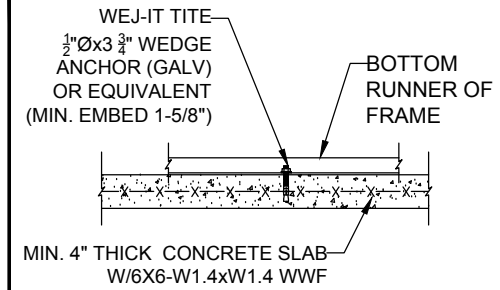

NOT TO SCALE

NOTE: LEAVE FLANGE NUT LOOSE UNTIL CLIPS HAVE BEEN SECURED TO PLANKS.

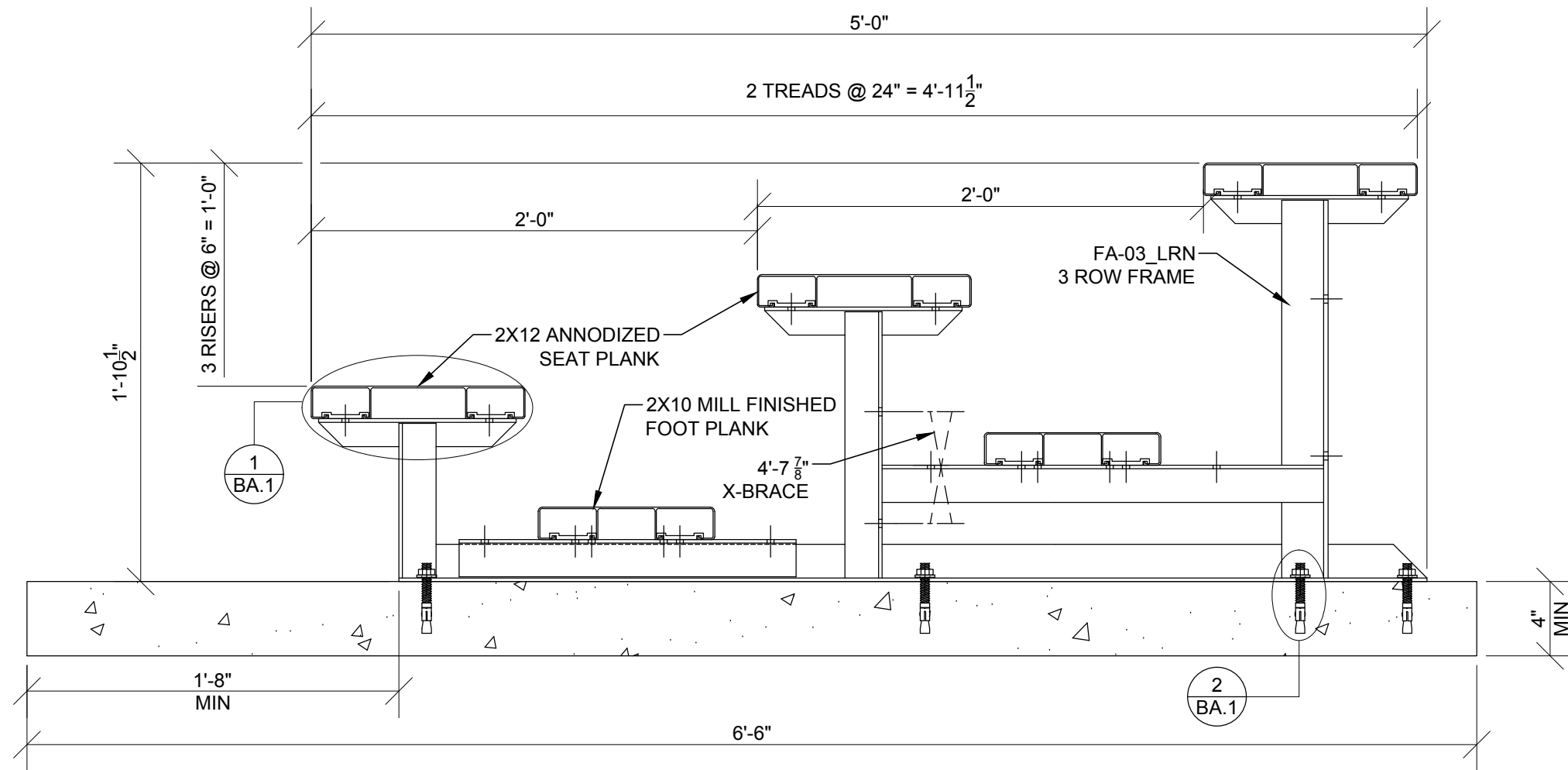

**BLEACHER ASSEMBLY**

SCALE: 1 1/2" = 1' - 0"

\*CONCRETE WEDGE ANCHORS NOT INCLUDED WITH ALL UNITS. IF USING OTHER ANCHORING SYSTEM, SKIP THIS STEP AND REFER TO INSTRUCTIONS SPECIFIC TO THE ANCHORING SYSTEM PURCHASED FOR YOUR UNIT. SEE PRINT FP.1 (INCLUDED IN THIS PACKET) FOR GENERAL CONCRETE FOUNDATION SPECIFICATIONS.



2810 Sydney Road  
Plant City, Florida 33566  
Phone: 813-305-1415  
Fax: 813-305-1419  
www.gtgrandstands.com

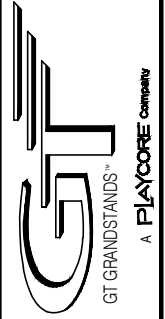

BLEACHER ASSEMBLY  
3 ROW BLEACHER  
6" RISE/12" SEAT

LU-0315AS  
(OPTIONAL CONCRETE FOUNDATION)  
LU SERIES

DRAWN BY  
MME  
CHECKED BY  
DATE  
07/18/17  
SCALE  
JOB NO.  
LU-0315AS  
DWG NO.  
BA.1



2810 Sydney Road  
 Plant City, Florida 33566  
 Phone: 813-305-1415  
 Fax: 813-305-1419  
 www.gtgrandstands.com

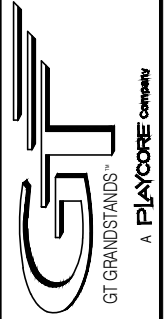

FOUNDATION PLAN  
 3 ROW BLEACHER  
 6" RISE/12" SEAT

LU-0315AS  
 LU SERIES

DRAWN BY  
 MME  
 CHECKED BY  
 DATE  
 07/18/17  
 SCALE  
 JOB NO.  
 LU-0315AS  
 DWG NO.  
 FP.1

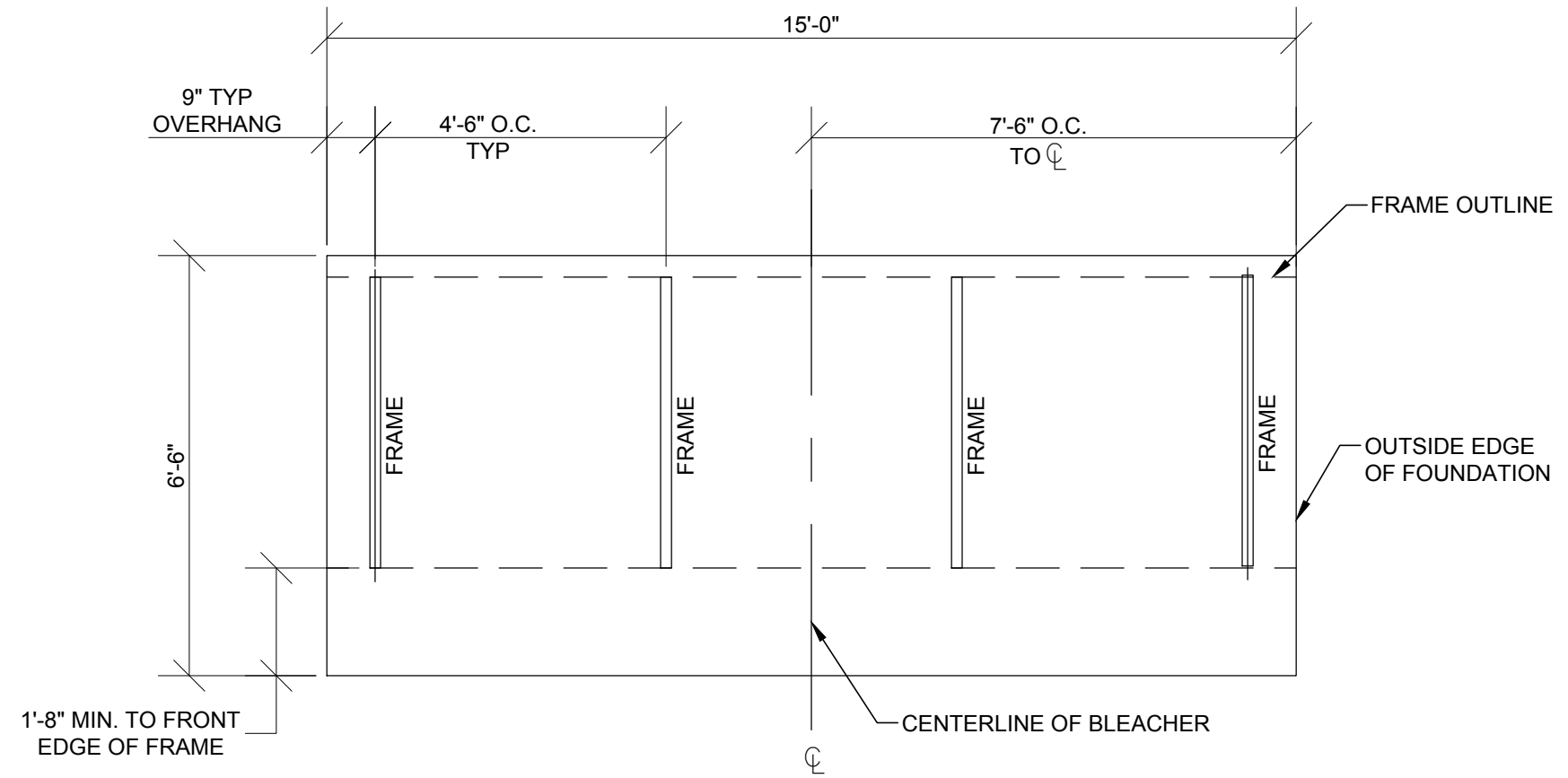

**OPTIONAL FOUNDATION PLAN\***  
 SCALE: 3/8" = 1' - 0"

\* MINIMUM FOUNDATION AREA SHOWN. DEPENDING ON LOCAL SOIL CONDITIONS, BLEACHER CAN BE INSTALLED ON A CONCRETE PAD OR FOOTERS, OR ATTACHED TO 2x6 TREATED LUMBER GROUND SILLS AND PLACED ON COMPACTED STONE, ASPHALT, OR ANY OTHER SMOOTH, SOLID, LEVEL SURFACE. CONSULT YOUR LOCAL CONCRETE CONTRACTOR TO DETERMINE PROPER CONCRETE SPECIFICATIONS FOR YOUR LOCAL SOIL AND WEATHER-RELATED CONDITIONS. THE BEARING SURFACE MUST BE CAPABLE OF SUPPORTING A MINIMUM OF 660 POUNDS PER LINEAR FOOT. TO MEET LOCAL CODES, BLEACHERS WILL NEED TO BE ANCHORED. ANCHORING SYSTEMS FOR ALL SURFACE TYPES ARE AVAILABLE - CONTACT YOUR BLEACHER SALES REPRESENTATIVE FOR MORE INFORMATION.