

# TIP - N - ROLL BLEACHER

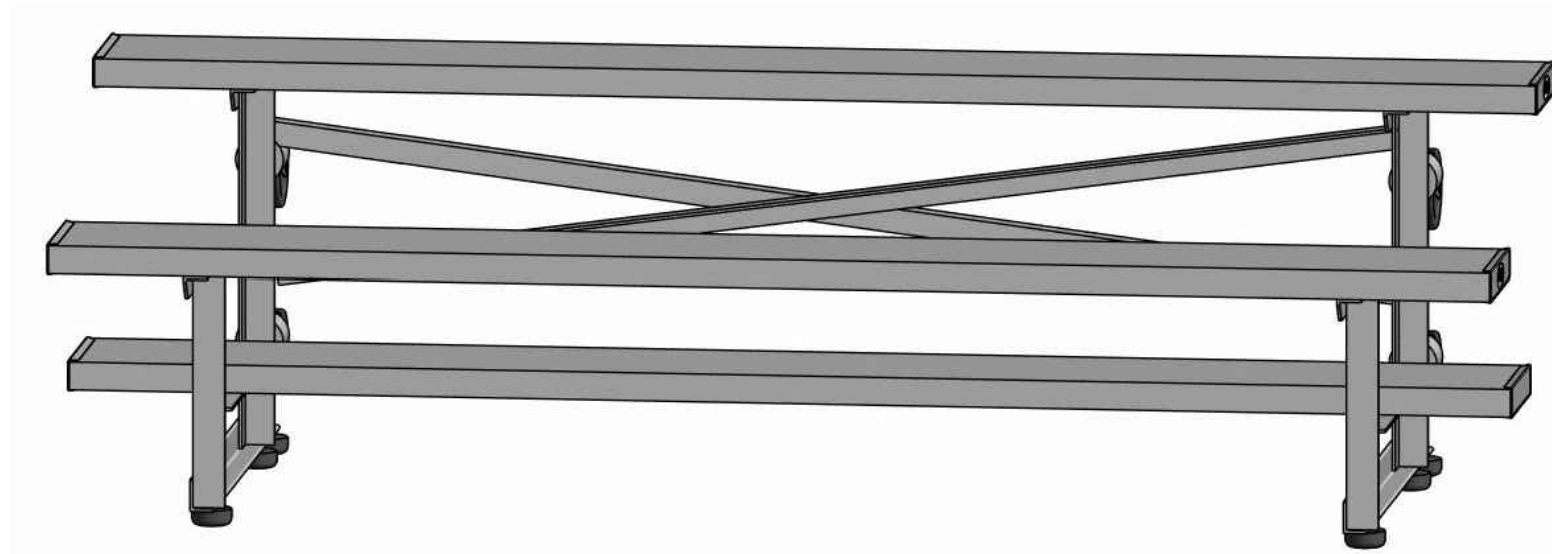

**ALUMINUM 2 ROW x 7'-6" - NATIONAL REP SERIES**

**MODEL  
NR-027.5AS-TR**



2810 Sydney Road  
Plant City, Florida 33566  
Phone: 813-305-1415  
Fax: 813-305-1419  
www.gtgrandstands.com

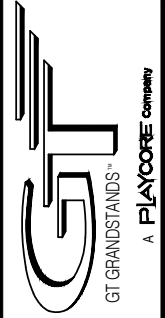

COVER SHEET  
2 ROW BLEACHER  
TIP - N - ROLL

NR-027.5AS-TR  
NR SERIES

DRAWN BY  
MME  
CHECKED BY  
TLC  
DATE  
4/28/2016  
SCALE  
JOB NO.

NR-027.5AS-TR  
DWG NO.

CS.1 - COVER SHEET  
SP.1 - BLEACHER SEATING PLAN  
BA.1 - BLEACHER ASSEMBLY  
PF.1 - PLANK & FRAME

CS.1



2810 Sydney Road  
 Plant City, Florida 33566  
 Phone: 813-305-1415  
 Fax: 813-305-1419  
 www.ggrandstands.com

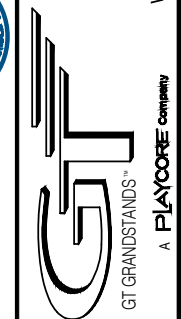

SEATING PLAN  
 2 ROW BLEACHER  
 TIP - N - ROLL

NR-027.5AS-TR  
 NR SERIES

DRAWN BY  
 MME  
 CHECKED BY  
 TLC  
 DATE  
 4/28/2016  
 SCALE  
 3/4" = 1' - 0"  
 JOB NO.  
 NR-027.5AS-TR  
 DWG NO.  
 SP.1

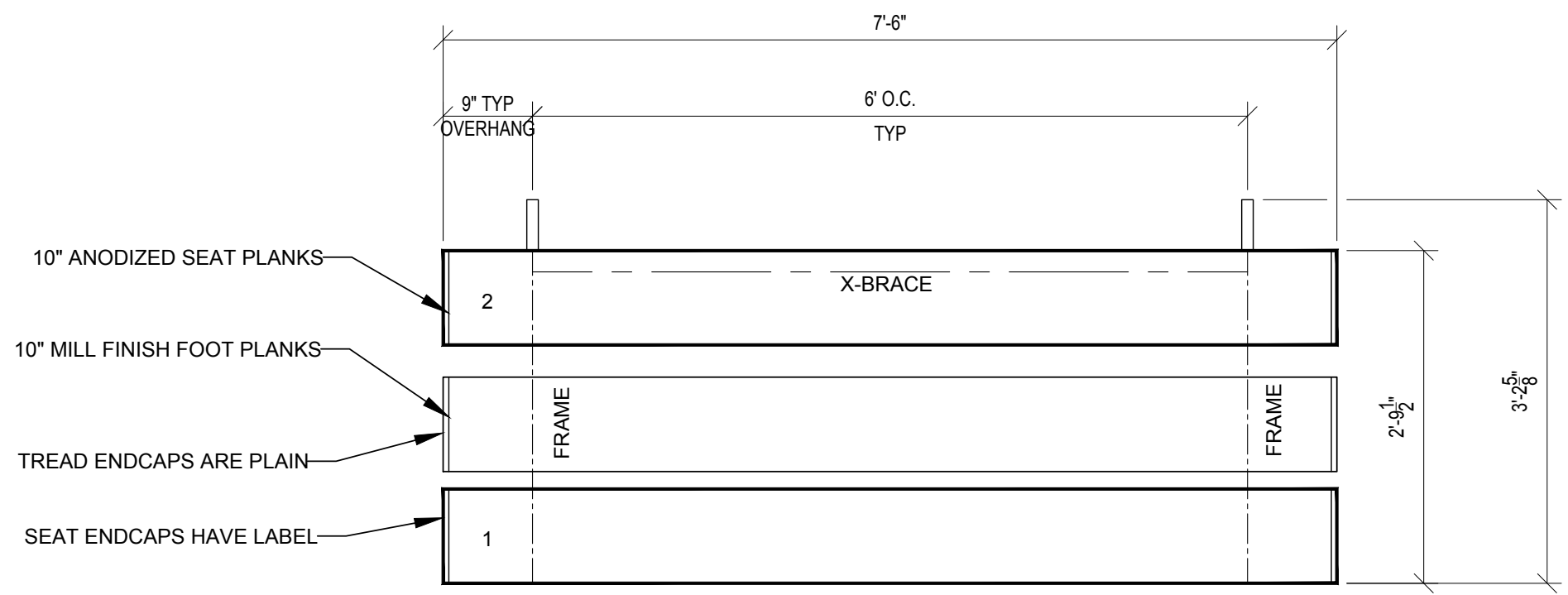

**SEATING PLAN**  
 SCALE: 3/4" = 1' - 0"

SECTION LENGTH	GROSS SEATS	ACTUAL SEATS	NO. OF ROWS	NET SEATS
7.5	5.00	5.00	2	10
				NET SEATS 10
				WHEELCHAIR SPACES 0
				<b>TOTAL NET SEATING CAPACITY 10</b>
				(BASED ON 18" PER SEAT)

LOCAL CODES AND SPECIFICATIONS WILL VARY FROM REGION TO REGION AND WILL ALSO CHANGE OVER TIME. IT IS THE BUYER'S RESPONSIBILITY TO CHECK LOCAL CODES FOR COMPLIANCE.

① TYP X-BRACE CONN. W/ 1 1/4 BOLT

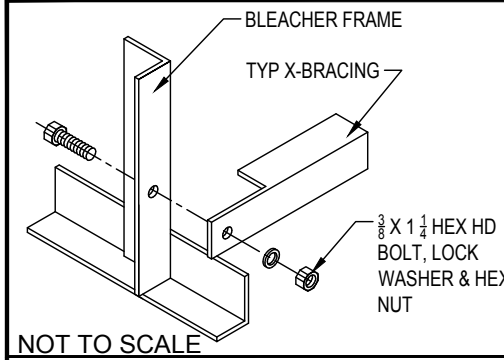

② TYP 2X10 PLANK ATTACH

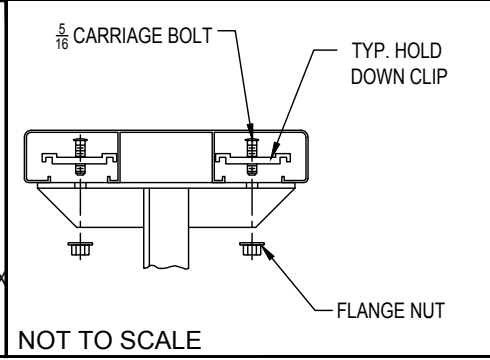

③ RUBBER FOOT PAD ATTACH. DETAIL

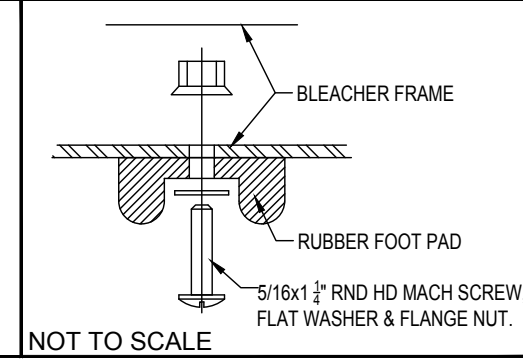

④ CASTER ATTACHMENT DETAIL

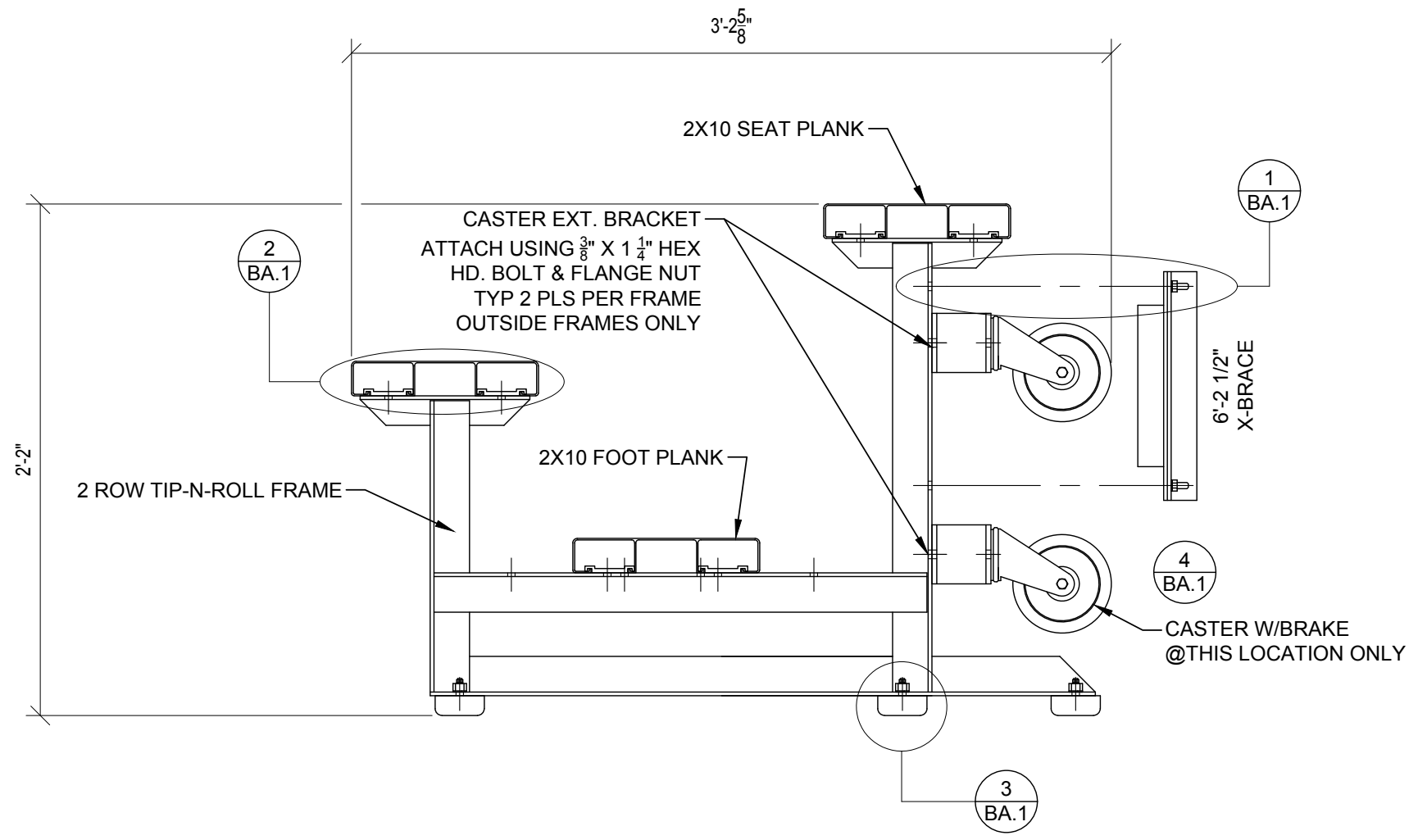
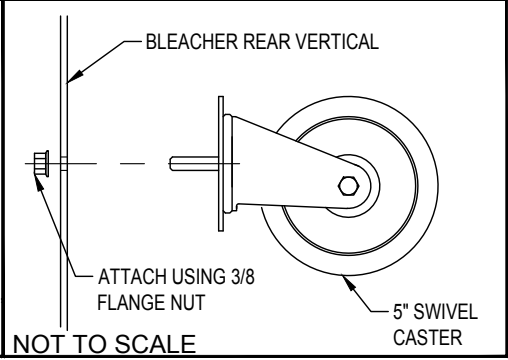

**BLEACHER ASSEMBLY ELEVATION**

SCALE: 1 1/2" = 1' - 0"

**WARNING**

TIP N' ROLL BLEACHERS ARE SUITABLE FOR INDOOR OR OUTDOOR USE. HOWEVER, THEY SHOULD ONLY BE TIPPED UP ON THE CASTERS INDOORS, DUE TO POTENTIAL WIND HAZARDS IF TIPPED UP OUTDOORS. THESE LIGHT-WEIGHT UNITS ARE EASILY TIPPED UP BY ANY RESPONSIBLE ADULT.



2810 Sydney Road  
Plant City, Florida 33566  
Phone: 813-305-1415  
Fax: 813-305-1419  
www.gtgrandstands.com

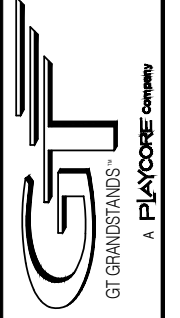

BLEACHER ASSEMBLY  
2 ROW BLEACHER  
TIP - N - ROLL

NR-027.5AS-TR  
NR SERIES

DRAWN BY  
MME  
CHECKED BY  
TLC  
DATE  
4/28/2016  
SCALE  
AS SHOWN  
JOB NO.

NR-027.5AS-TR  
DWG NO.

BA.1

① TYP X-BRACE CONN. W/ 1 1/4" BOLT

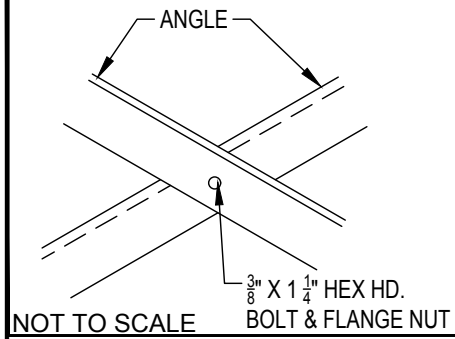

② TYP 2x10 ENDCAP ATTCH. W/LABEL

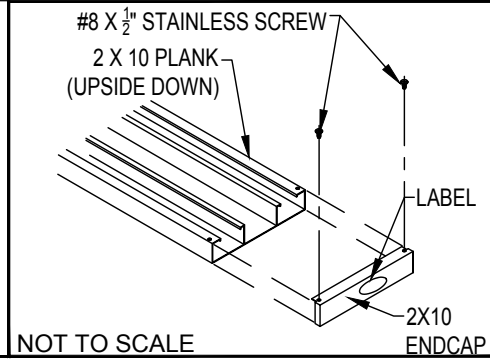

③ TYP 2x10 ENDCAP ATTACHMENT

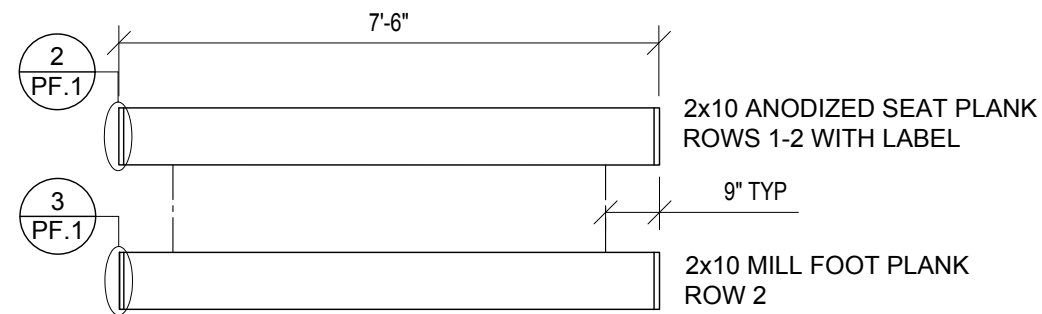
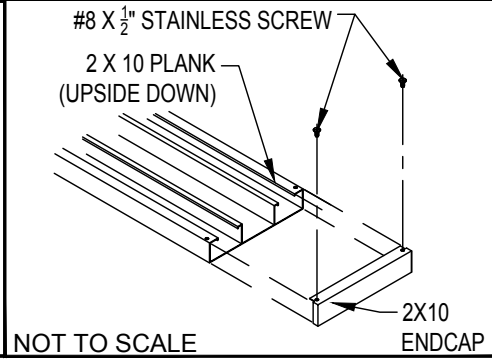

**PLANK PLAN**  
SCALE: 3/8" = 1' - 0"

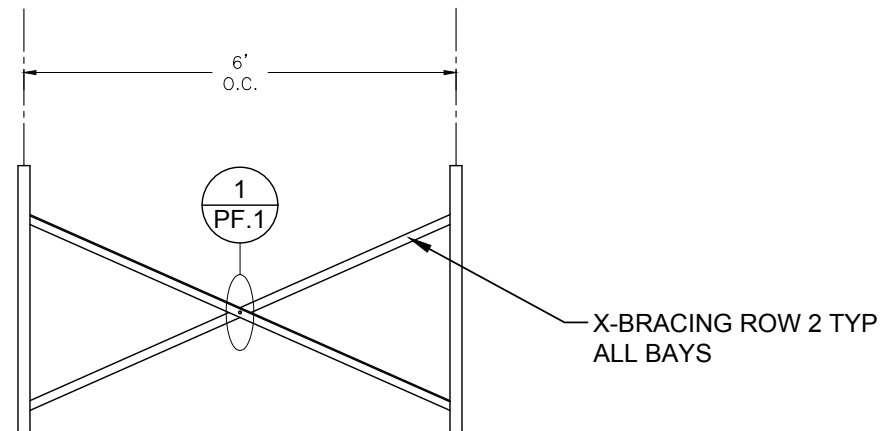

**FRAME SECTION**  
SCALE: NTS



2810 Sydney Road  
Plant City, Florida 33566  
Phone: 813-305-1415  
Fax: 813-305-1419  
www.gtgrandstands.com

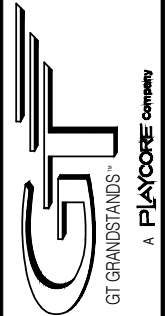

PLANK AND FRAME  
2 ROW BLEACHER  
TIP - N - ROLL

NR-027.5AS-TR  
NR SERIES

DRAWN BY  
MME  
CHECKED BY  
TLC  
DATE  
4/28/2016  
SCALE  
3/4" = 1' - 0"  
JOB NO.

NR-027.5AS-TR  
DWG NO.

PF.1