

TIP - N - ROLL BLEACHER

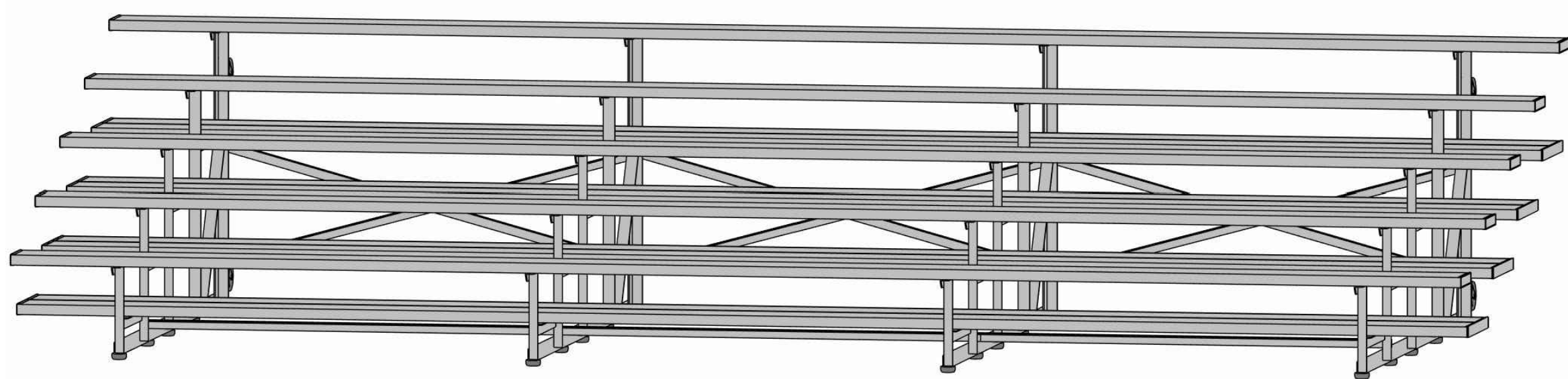

ALUMINUM 5 ROW x 21'-0" - NATIONAL REP SERIES

MODEL
NR-0521AD-TR



2810 Sydney Road
Plant City, Florida 33566
Phone: 813-305-1415
Fax: 813-305-1419
www.gtgrandstands.com

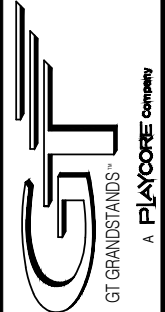

COVER SHEET
5 ROW BLEACHERS
TIP - N - ROLL

NR-0521AD-TR
NR SERIES

DRAWN BY
MME
CHECKED BY
TLC
DATE
09/10/2016
SCALE
JOB NO.

NR-0521AD-TR
DWG NO.

- CS.1 - COVER SHEET
- SP.1 - BLEACHER SEATING PLAN
- BA.1 - BLEACHER ASSEMBLY
- PF.1 - PLANK & FRAME

CS.1



2810 Sydney Road
 Plant City, Florida 33566
 Phone: 813-305-1415
 Fax: 813-305-1419
 www.gtgrandstands.com

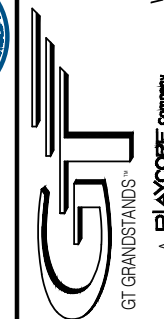

SEATING PLAN
 5 ROW BLEACHERS
 TIP - N - ROLL

NR-052IAD-TR
 NR SERIES

DRAWN BY
 MME
 CHECKED BY
 TLC
 DATE
 09/10/2016
 SCALE
 1/2" = 1' - 0"
 JOB NO.

NR-052IAD-TR
 DWG NO.

SP.1

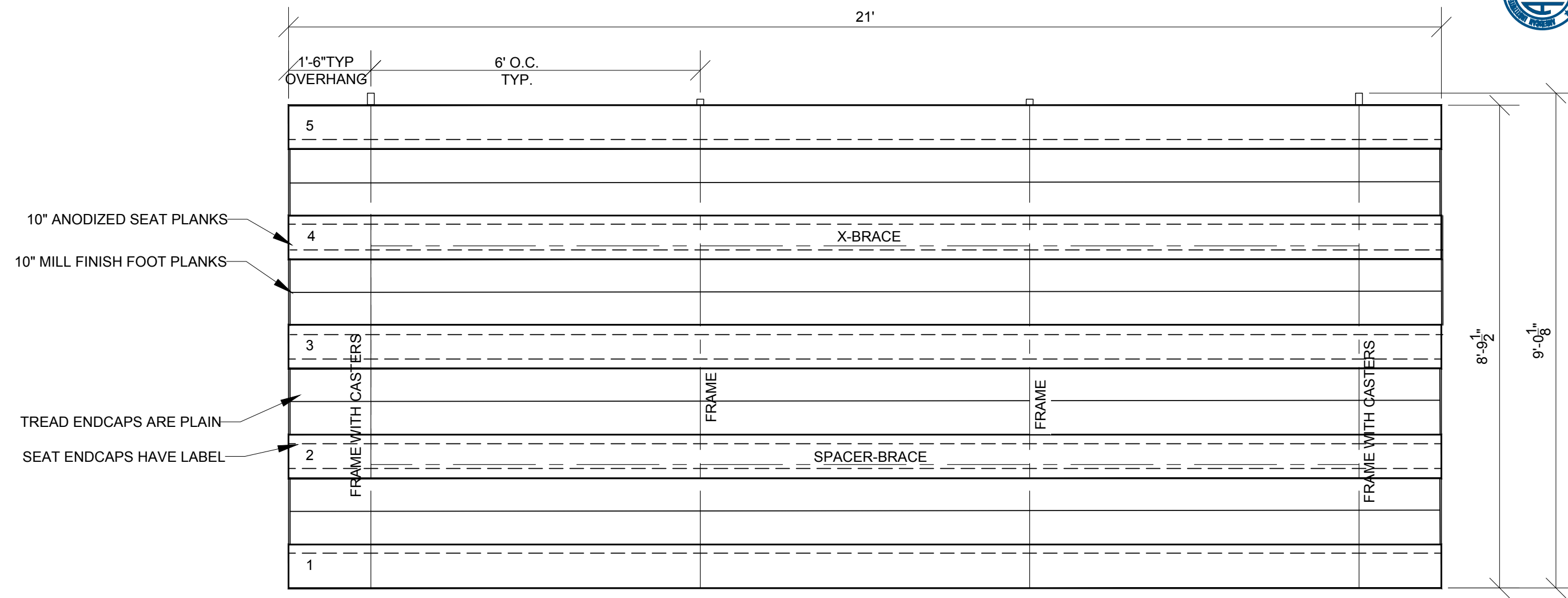

SEATING PLAN
 SCALE: 1/2" = 1' - 0"

SECTION LENGTH	GROSS SEATS	ACTUAL SEATS	NO. OF ROWS	NET SEATS
21	14.00	14.00	5	70
				NET SEATS 70
				WHEELCHAIR SPACES 0
				TOTAL NET SEATING CAPACITY 70
				(BASED ON 18" PER SEAT)

LOCAL CODES AND SPECIFICATIONS WILL VARY FROM REGION TO REGION AND WILL ALSO CHANGE OVER TIME. IT IS THE BUYER'S RESPONSIBILITY TO CHECK LOCAL CODES FOR COMPLIANCE.

① TYP X-BRACE CONN. W/ 1/4 BOLT

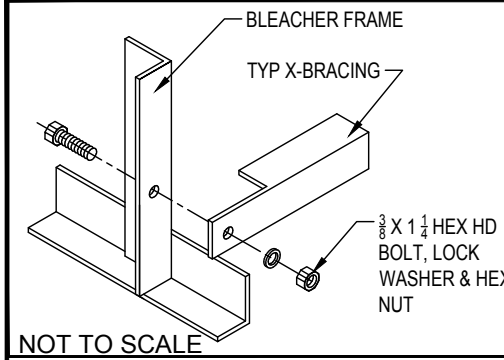

② TYP 2X10 PLANK ATTACH

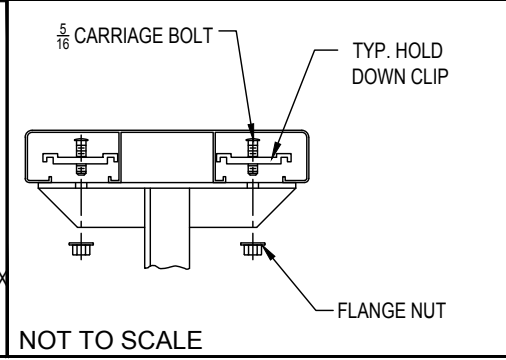

③ RUBBER FOOT PAD ATTACH. DETAIL

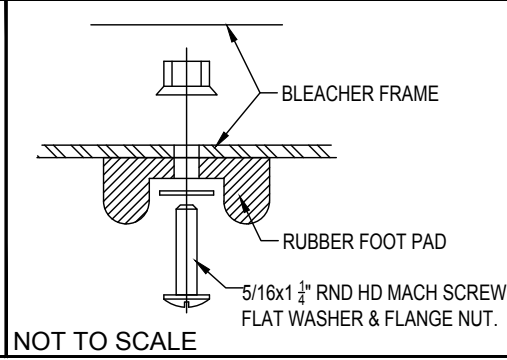

④ CASTER ATTACHMENT DETAIL

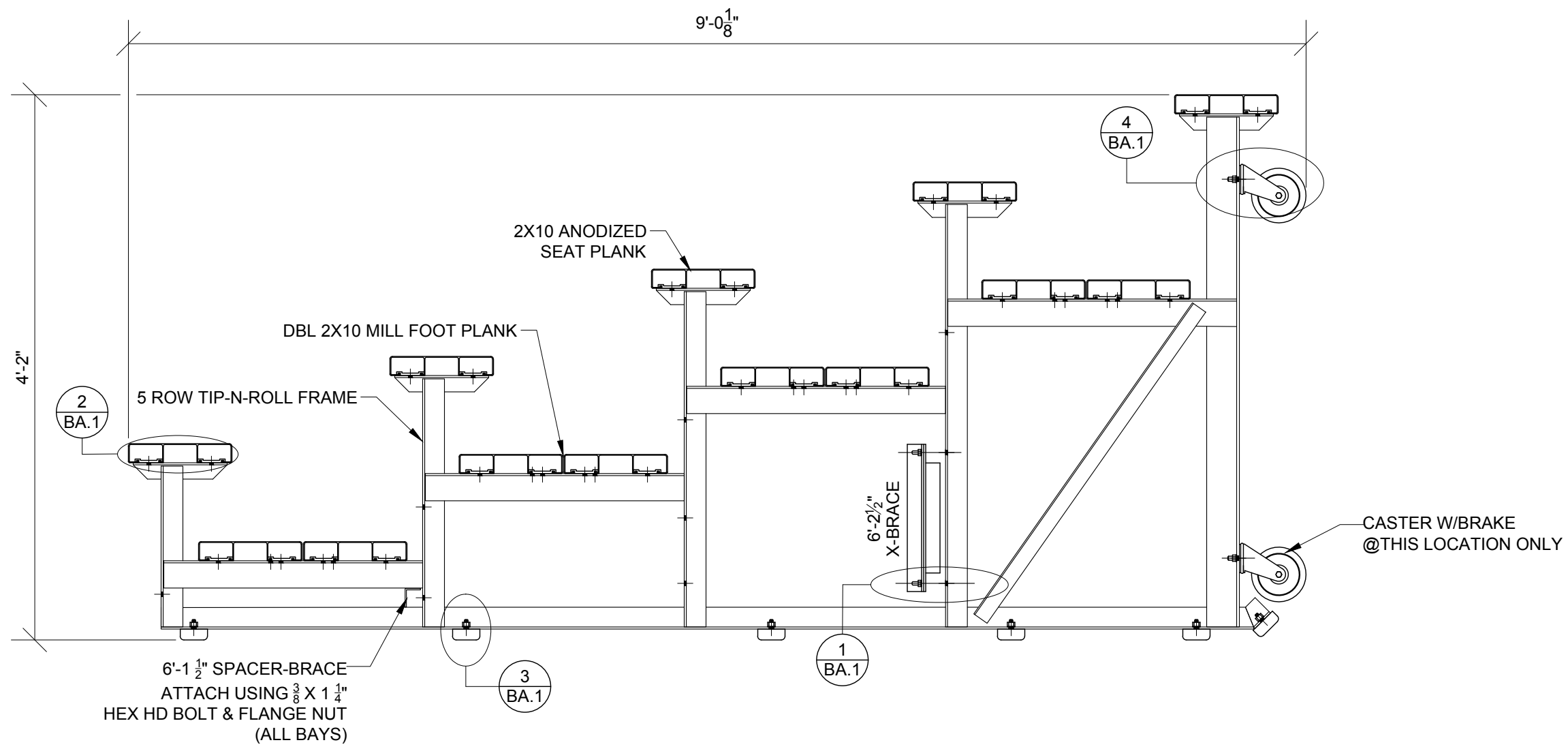
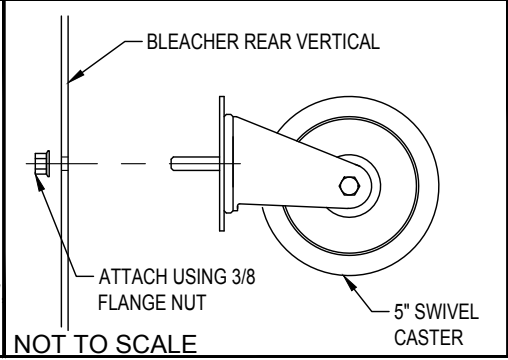

BLEACHER ASSEMBLY ELEVATION
SCALE: 1" = 1' - 0"

WARNING

TIP N' ROLL BLEACHERS ARE SUITABLE FOR INDOOR OR OUTDOOR USE. HOWEVER, THEY SHOULD ONLY BE TIPPED UP ON THE CASTERS INDOORS, DUE TO POTENTIAL WIND HAZARDS IF TIPPED UP OUTDOORS. THESE LIGHT-WEIGHT UNITS ARE EASILY TIPPED UP BY ANY RESPONSIBLE ADULT.

NOTE: MOUNT CASTERS TO END FRAMES ONLY



2810 Sydney Road
Plant City, Florida 33566
Phone: 813-305-1415
Fax: 813-305-1419
www.gtgrandstands.com

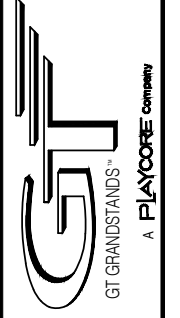

BLEACHER ASSEMBLY
5 ROW BLEACHERS
TIP - N - ROLL

NR-052IAD-TR
NR SERIES

DRAWN BY
MME
CHECKED BY
TLC
DATE
09/10/2016
SCALE
AS SHOWN
JOB NO.

NR-052IAD-TR
DWG NO.

BA.1

① TYP X-BRACE CONN. W/ 1 1/4" BOLT

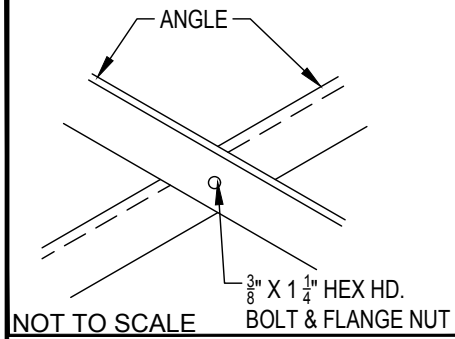

② TYP 2x10 ENDCAP ATTCH.

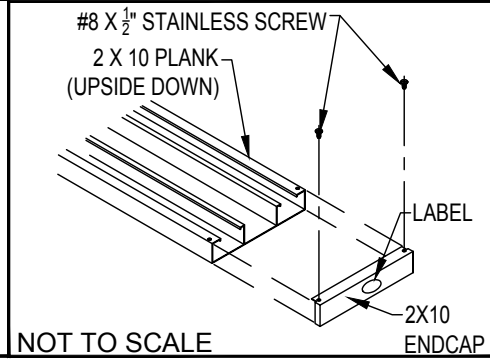

③ DBL. 2x10 ENDCAP ATTACHMENT

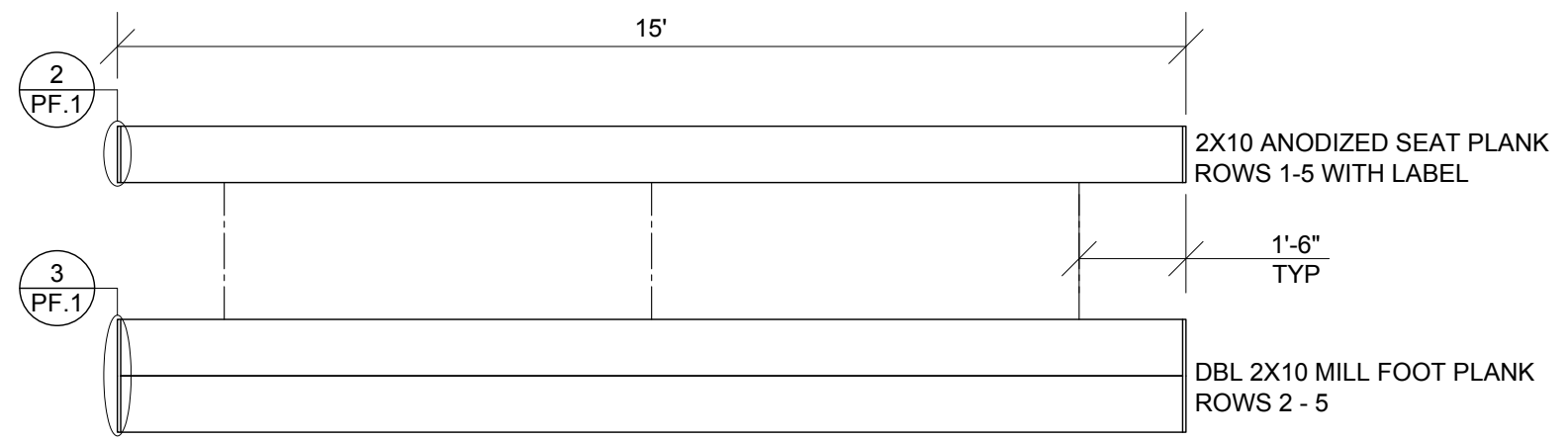
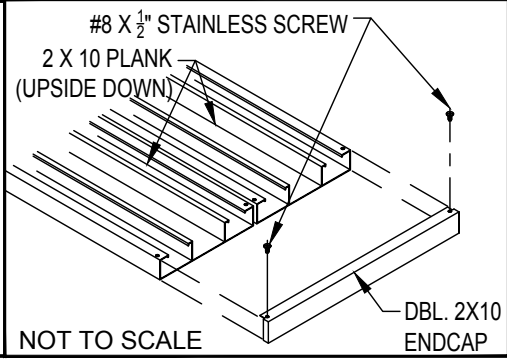

PLANK PLAN
SCALE: 3/8" = 1' - 0"

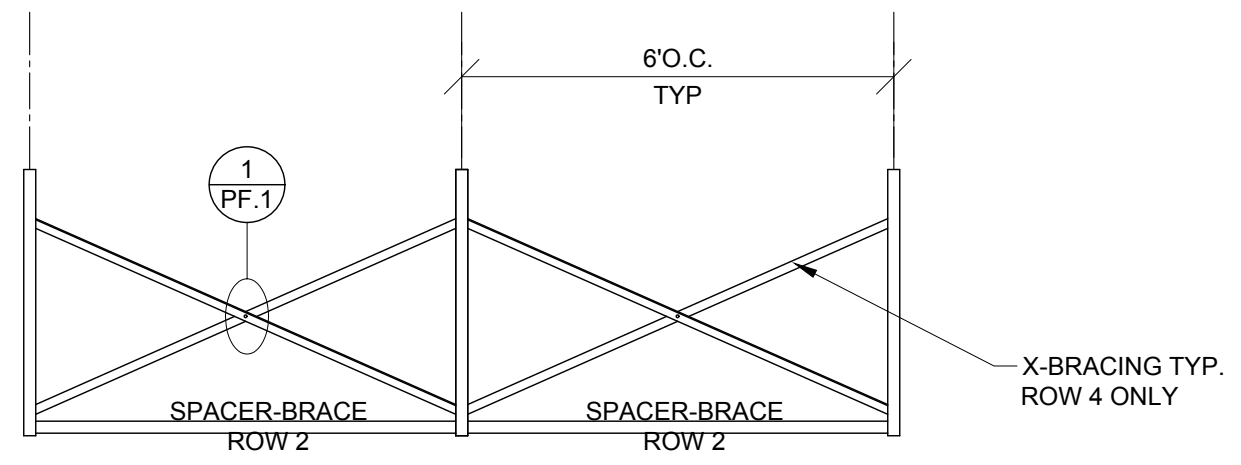

FRAME SECTION
SCALE: NTS



2810 Sydney Road
Plant City, Florida 33566
Phone: 813-305-1415
Fax: 813-305-1419
www.gtgrandstands.com

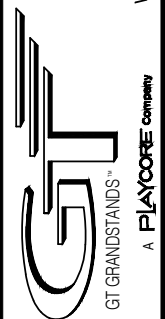

PLANK AND FRAME
5 ROW BLEACHERS
TIP - N - ROLL

NR-052IAD-TR
NR SERIES

DRAWN BY
MME
CHECKED BY
TLC
DATE
09/10/2016
SCALE
AS SHOWN
JOB NO.

NR-052IAD-TR
DWG NO.